



## Data Sheet

---

Customer: \_\_\_\_\_

Part No: \_\_\_\_\_

CLT-138LM(N)

Sample No: \_\_\_\_\_

Description: \_\_\_\_\_

IR Receiver Module

Item No: \_\_\_\_\_

Customer			
Check	Inspection	Approval	Date

## ◆ Description

The CLT-xxx(N) Series are miniaturized receiver for infrared remote control system.

A PIN Photodiode and preamplifier are assembled on lead frame, the epoxy package is designed as IR filter. The module has excellent performance even in disturbed ambient light application and provides protection against uncontrolled output pulses.

This component has not been qualified according to automotive specifications.

## ◆ Features

- Photo detector and preamplifier in one package
- Low supply current
- Wide operating voltage : 2.7V ~ 5.5 V
- Available for Carrier Frequencies between 32.7kHz to 56kHz,
- Internal filter for PCM frequency
- Insensitive to supply voltage ripple and noise
- Improved shielding against EMI
- Improved immunity against ambient light (Built-in Filter & AGC Circuit)
- Open collector output (Built-in inter pull-up resistor – typ. 50 k $\Omega$  )
- Short settling time after power On ( below 100msec)



## ◆ Applications

- TV, VCR, AUDIO
- Home Appliances
- Remote Control Equipment

## ◆ Ordering Info.(Carrier frequencies)

Type	Carrier Frequency
CLT-x32xx(N)-X	32.7 kHz
CLT-x37xx(N)-X	36.7 kHz
CLT-x38xx(N)-X	37.9 kHz
CLT-x40xx(N)-X	40.0 kHz
CLT-x56xx(N)-X	56.7 kHz

## ◆ Block Diagram

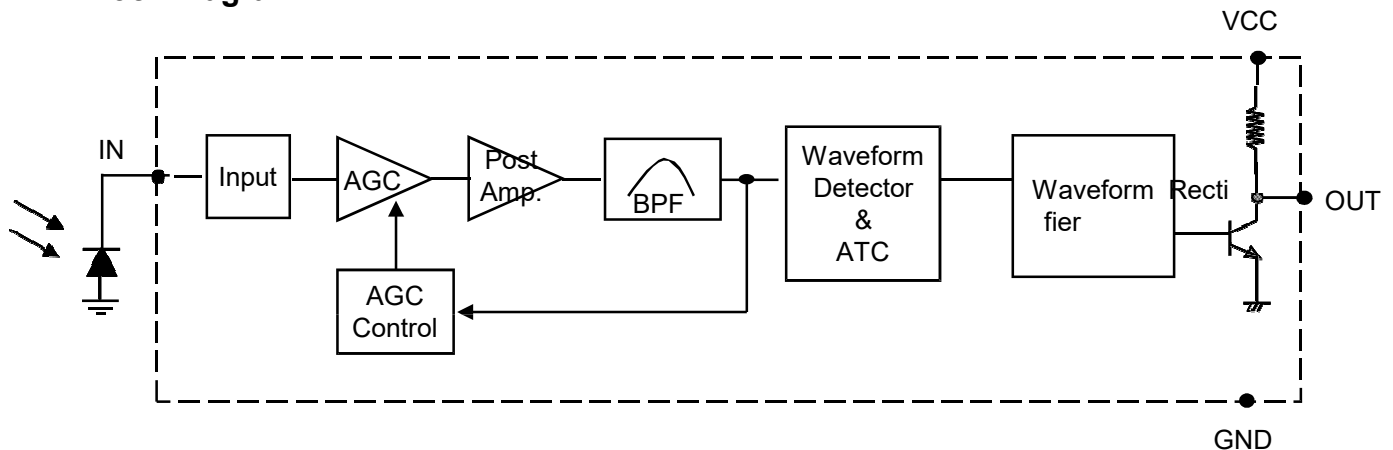

**◆ Absolute Maximum Ratings**

(Ta = 25 °C)

Parameter	Symbol	Min.	Max.	Unit
Supply Voltage	VCC	0	6.0	V
Supply Current	ICC	0	3.0	mA
Output Voltage	Vout	0	6.0	V
Output Current	Iout	0	2.5	mA
Storage Temperature	Tstg	-30	85	°C
Soldering Temperature	Tsd	260 °C ± 5 °C, Max 5 sec		°C

\* Stress above those listed under “Absolute Maximum Ratings” may cause permanent damage of device. This is stress rating only and functional operation of the device at these or any other conditions above those indicated in the operational sections of this specification is not implied. Exposure to absolute maximum rating conditions for longer periods may affect device reliability.

**◆ Recommended operating Conditions**

Parameter	Symbol	Min.	Max.	Unit
Operating Voltage	VCC	2.7	5.5	V
Input Frequency	fin	32	40	kHz
Operating temperature	Tamb	-20	80	°C

**◆ Electro-optical Characteristics**

(Ta = 25 °C)

Parameter	Symbol	Conditions	Min	Typ	Max	Unit	
Operating Voltage	Vcc	-	2.7	-	5.5	V	
Supply Current	Icc	No input signal	Vcc=5V	0.3	0.53	0.7	mA
			Vcc=3V	0.2	0.4	0.6	
Peak Wave Length (*1)	$\lambda_P$		-	940	-	nm	
B.P.F Center Frequency (*2)	f <sub>o</sub>		-	37.9	-	KHz	
High Level Output Voltage (*1)	V <sub>OH</sub>	30cm over the ray axis	Vcc-0.2	-	-	V	
Low Level Output Voltage (*1)	V <sub>OL</sub>		-	0.2	0.4	V	
High Level Output Pulse Width (*1)	T <sub>WH</sub>	Burst Wave = 600 $\mu$ s Period = 1.2ms	400	600	800	$\mu$ s	
Low Level Output Pulse Width (*1)	T <sub>WL</sub>		400	600	800	$\mu$ s	
Arrival Distance (*1)	L	Fig. 1,2,3	± 0°	-	25	-	m
			± 30°	-	18	-	
			± 45°	-	12	-	
Output Form	Active Low						

※ 1. 600/600 $\mu$ s burst wave is transmitted by standard(Fig.2, Fig.3) transmitter. However, it measured after the initial transmission pulse is 10(60ms) pulse.

Arrival Distance Effected by Environment

※ 2. The following band pass frequencies are available.(32.7kHz/36.7kHz/37.9kHz/40kHz)  
Carrier frequencies adjusted by zener-diode fusing method.

◆ **Measurement Conditions (Ta=25°)**

[ Fig.1 ] **Output Waveform**

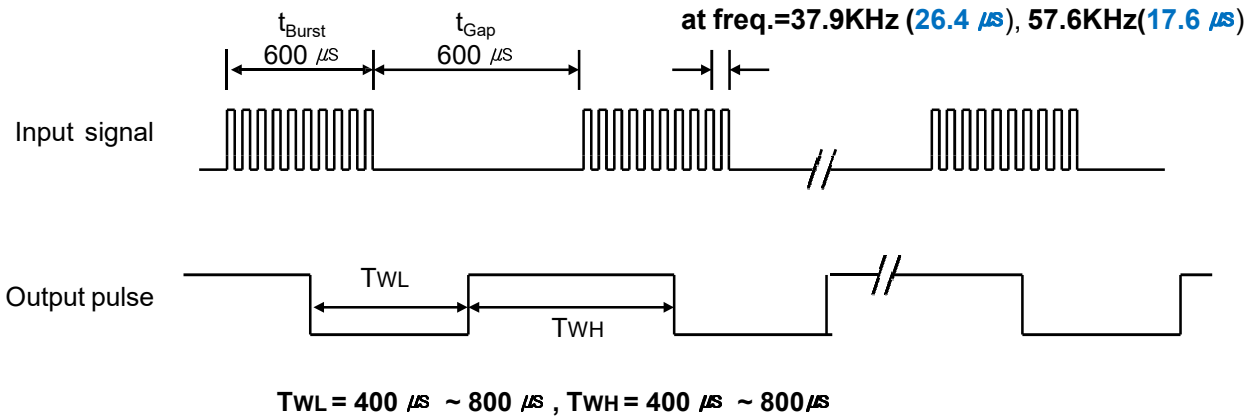

[ Fig.2 ] **Transmitter**

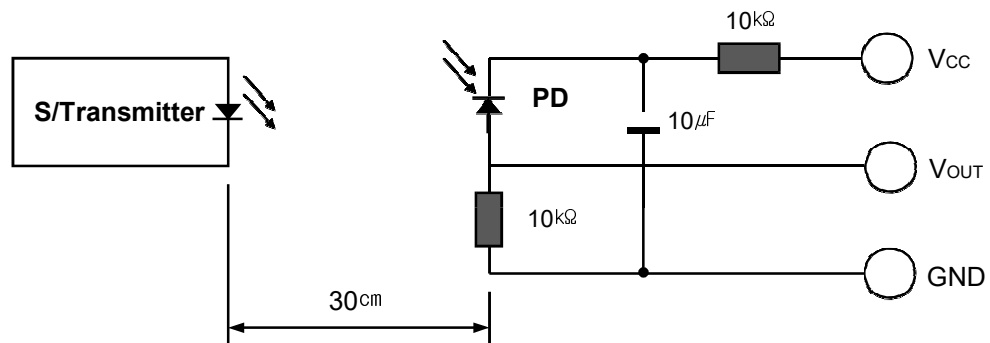

※ The specifications shall be satisfied under the following conditions. The standard transmitter shall be specified of the burst wave form adjusted to V<sub>OUT</sub> 200mVp-p upon Po measuring circuit Standard Transmitter

[ Fig.3 ] **Test condition of arrival distance**

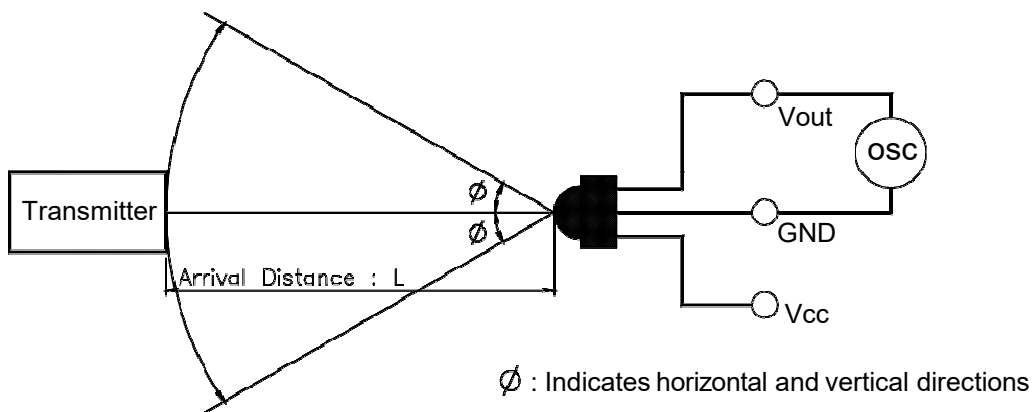

[ Measurement condition for arrival distance ]

☞ Ambient light source : Detecting surface illumination shall be irradiate 200± 50Lux under ordinary white fluorescence lamp without high frequency lighting

◆ **Electrical / Optical Characteristics (Ta=25 )**

[ Fig.4 ] Supply Current vs. Voltage

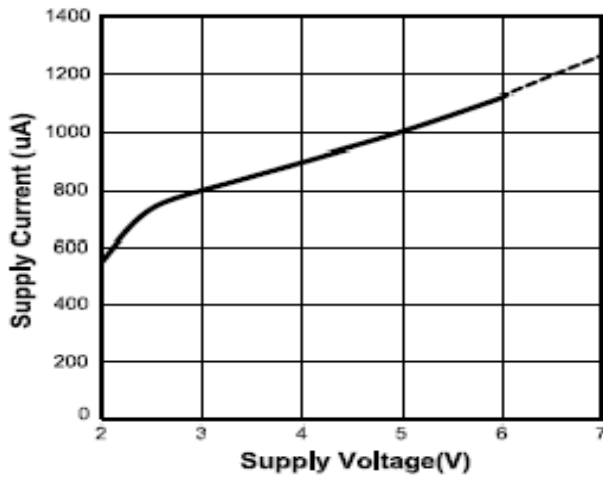

[ Fig.5 ] Relative Spectral Sensitivity

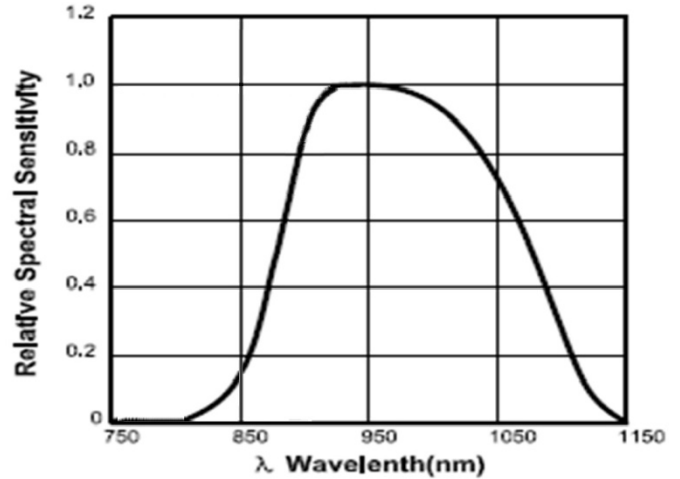

[ Fig.6 ] Output Pulse Width vs. Distance

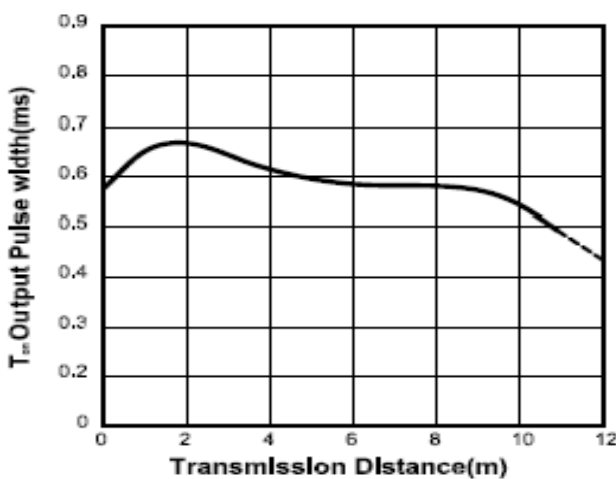

[ Fig.7 ] Directivity

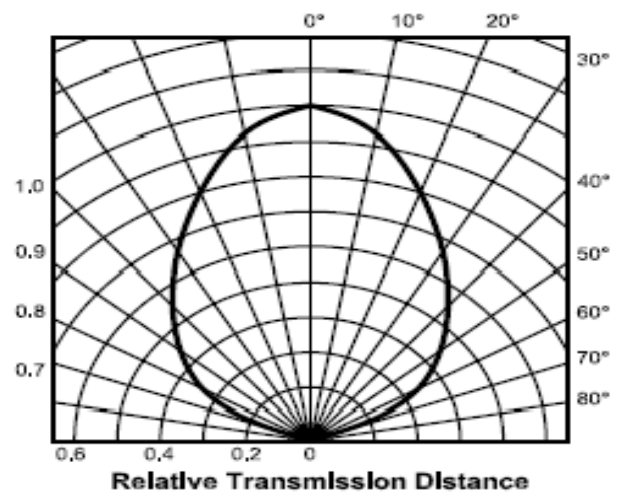

[ Fig.8 ] B.P.F Fc Curve

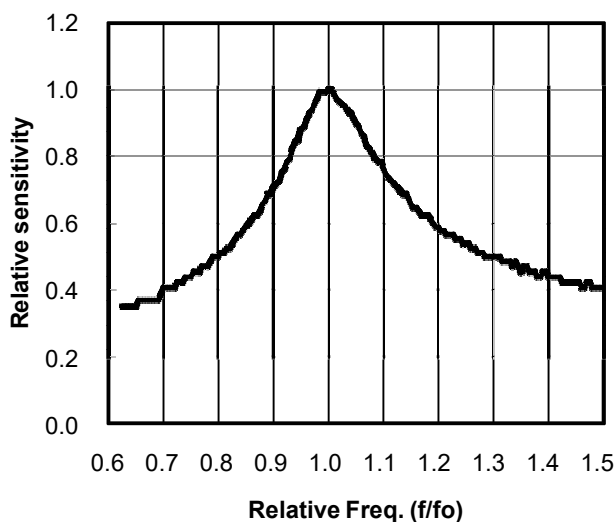

**ESD Test Results**

Parameter	Specification	Results
Machine Model	Min ± 200V	> ± 400V
Human Body Model	Min ± 2000V	> ± 4000V
Charged Device Model	Min ± 400V	> ± 600V

◆ **Suitable Data format for the CLT-xxx(N) Series ;**

The circuit of the CLT-xxx(N) series is designed in that way that unexpected output pulses due to noise or disturbance signals are avoided. A band pass filter, an integrator stage and an automatic gain control are used to suppress such disturbances.

The distinguishing mark between data signal (not suppressed) and disturbance signal (suppressed) are carrier frequency, burst length and Signal Gap Time (see diagram below).

➤ The data signal should full-fill the following condition :  
Carrier frequency should be close to center frequency of the band-pass filter.

➤ Some examples for suitable data format are :  
NEC , RC5/6, Toshiba , Sony12bit , Matsushita , Mitsubishi Code.  
( Sony15/20 bit ,RCA, RCMM Code is not Recommend. )

Item	Symbol	Time
Minimum Burst length	tBurst	Min. 300us
Minimum Gap Time	tGap	Min. 350us
Minimum data pause time	tPause	Min. 23ms
Required data pause time	tPause	> (DWT/ 3) + 18.5ms

[ Fig. 9 ] Data Signal diagram

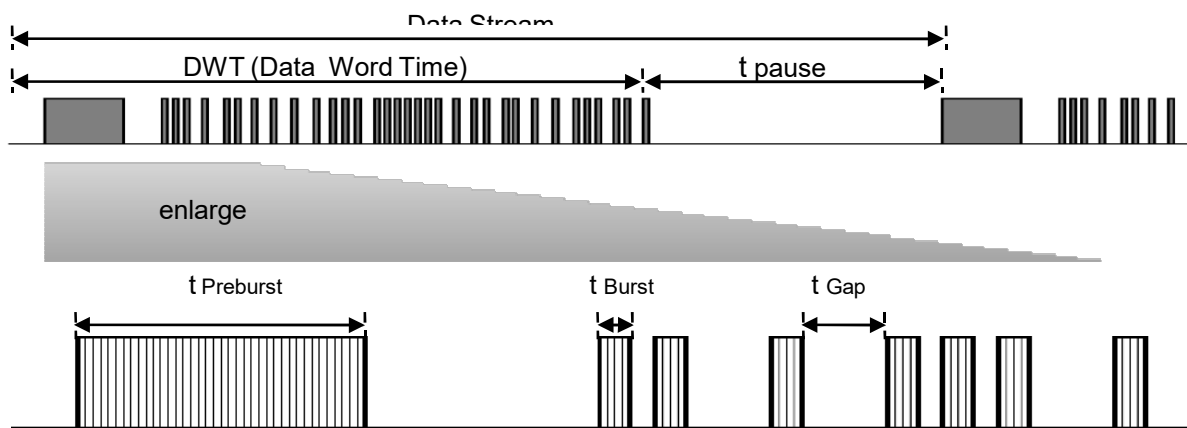

- t Burst ; length of a burst in pulses of the carrier frequency.
- t Gap ; length of the gap between two burst in pulses of carrier.
- t pause ; length of the pause between two data words.
- tPreburst ; lead code of data word

◆ **Disturbance Suppression**

When a disturbance signal is applied to the CLT-xxx(N) series. it can still receive the data signal. However the sensitivity is reduced to that level that no unexpected pulses will occurrence.

Some examples for such disturbance signals which are suppressed by the CLT-xxx(N) series are :

- Signals from fluorescent lamps with electronic ballast with high or low modulation.
- Continuous signal at 38 kHz or at any other frequency,
- DC light (from tungsten bulb or sunlight)

◆ **External Application Circuit - Power Noise reduction & ESD Protection**

A further influence to the IR receiver modules may come from a supply voltage which is not stable. Such a disturbed supply voltage can be caused by switching power supply.

which is not filtered well or by other components in the circuit which produced spikes on the supply line.

This disturbed supply will reduce the sensitivity of receiver modules.

This application circuit will filter the disturbed supply voltage.

**Receiver Module**

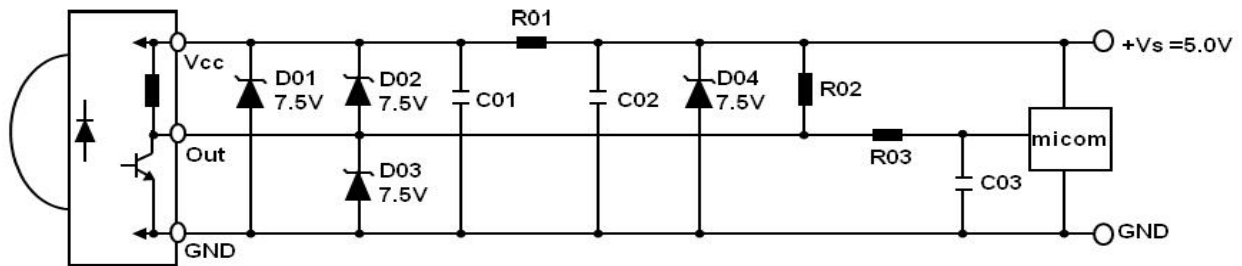

Component	Recommend
1) R01 (Vcc Input Series Resistance)	Typ. 100ohm (47 ohm ~ 470ohm)
2) R02 (Vcc-Vout Outer Pullup Resistance)	Optional (10K ohm or more)
3) R03 (Vcc-Vout Outer Pullup Resistance)	Typ. 330ohm (100 ohm ~ 1Kohm)
4) C01 (Vcc-GND Parallel Condenser)	Typ. 100uF (47uF ~ 100uF) / 6.3V
5) C02 (Vcc-GND Parallel Condenser)	Typ. 10nF (1nF ~ 100nF) / 6.3V
6) C03 (Vout-GND Parallel Condenser)	Typ. 2nF (1nF ~ 10nF) / 6.3V
7) D01~D04 (ESD Protection device)	Zener diode or TVS Protection diode

◆ **Reliability Test Items**

Parameter	Test conditions	Remark
High Temperature	Ta=+70, Vcc=5.0V t=240h	※ 1, ※ 2
Low Temperature	Ta=-20, Vcc=5.0V t=240h	※ 1, ※ 2
High Temp./ High Humidity	Ta=+60℃ 90%RH, Vcc=5.0V t=240h	※ 1, ※ 2
Heat Cycle	Ta=-30℃(0.5h) to +80℃(0.5h) 20 cycle	※ 2, ※ 3
Fall Test	Height=75cm, 3 times	※ 4

※ 1. Supply voltage of load test is 5V.

※ 2. Electro-optical characteristics shall be satisfied after leaving 2 hours in the normal condition.

※ 3. Heat cycle test shall repeat above condition 20 times under no load.

※ .

cm.

◆ **Material Configuration**

Parameter	Configuration	Remark
IC	Silicon(99%)	
Photo diode	Silicon(99%)	
Lead frame	Iron(99.5%), Silver(0.5%)	
Epoxy resin	Resin(55.5%), Hardener(45.5%)	
Silver epoxy	Silver(80%), Resin(10%), Hardener(10%)	
Bond wire	Gold(99.99%)	
Shield Case	Iron(99%), Tin(1%)	

◆ **Appearance & Dimensions (Unit : mm)**

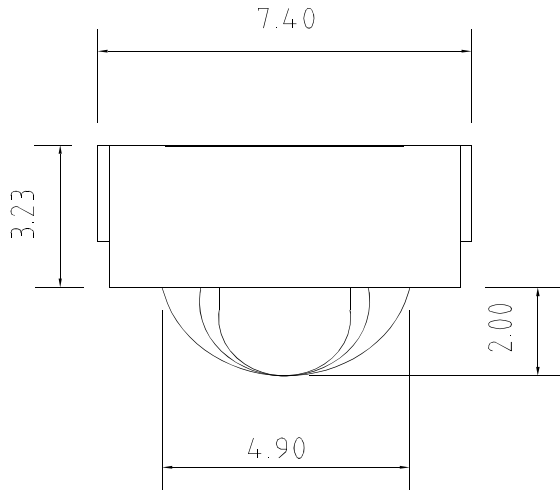

NOTE:

1. PIN CONFIG.

① Vout

② GND

③ Vcc

2. G.T  $\pm 0.3$

(UNIT:mm)

